

TECHNICAL REPORT



**Equipment for general lighting purposes – EMC immunity requirements–
Part 1: An objective light flickermeter and voltage fluctuation immunity test
method**



THIS PUBLICATION IS COPYRIGHT PROTECTED

Copyright © 2017 IEC, Geneva, Switzerland

All rights reserved. Unless otherwise specified, no part of this publication may be reproduced or utilized in any form or by any means, electronic or mechanical, including photocopying and microfilm, without permission in writing from either IEC or IEC's member National Committee in the country of the requester. If you have any questions about IEC copyright or have an enquiry about obtaining additional rights to this publication, please contact the address below or your local IEC member National Committee for further information.

IEC Central Office
3, rue de Varembe
CH-1211 Geneva 20
Switzerland

Tel.: +41 22 919 02 11
Fax: +41 22 919 03 00
info@iec.ch
www.iec.ch

About the IEC

The International Electrotechnical Commission (IEC) is the leading global organization that prepares and publishes International Standards for all electrical, electronic and related technologies.

About IEC publications

The technical content of IEC publications is kept under constant review by the IEC. Please make sure that you have the latest edition, a corrigenda or an amendment might have been published.

IEC Catalogue - webstore.iec.ch/catalogue

The stand-alone application for consulting the entire bibliographical information on IEC International Standards, Technical Specifications, Technical Reports and other documents. Available for PC, Mac OS, Android Tablets and iPad.

IEC publications search - www.iec.ch/searchpub

The advanced search enables to find IEC publications by a variety of criteria (reference number, text, technical committee,...). It also gives information on projects, replaced and withdrawn publications.

IEC Just Published - webstore.iec.ch/justpublished

Stay up to date on all new IEC publications. Just Published details all new publications released. Available online and also once a month by email.

Electropedia - www.electropedia.org

The world's leading online dictionary of electronic and electrical terms containing 20 000 terms and definitions in English and French, with equivalent terms in 16 additional languages. Also known as the International Electrotechnical Vocabulary (IEV) online.

IEC Glossary - std.iec.ch/glossary

65 000 electrotechnical terminology entries in English and French extracted from the Terms and Definitions clause of IEC publications issued since 2002. Some entries have been collected from earlier publications of IEC TC 37, 77, 86 and CISPR.

IEC Customer Service Centre - webstore.iec.ch/csc

If you wish to give us your feedback on this publication or need further assistance, please contact the Customer Service Centre: csc@iec.ch.

TECHNICAL REPORT



**Equipment for general lighting purposes – EMC immunity requirements–
Part 1: An objective light flickermeter and voltage fluctuation immunity test
method**

INTERNATIONAL
ELECTROTECHNICAL
COMMISSION

ICS 29.140.20

ISBN 978-2-8322-4904-8

Warning! Make sure that you obtained this publication from an authorized distributor.

CONTENTS

FOREWORD.....	4
INTRODUCTION.....	6
1 Scope.....	7
2 Normative references	7
3 Terms, definitions, abbreviated terms and symbols.....	8
3.1 Terms and definitions.....	8
3.2 Abbreviated terms.....	9
3.3 Symbols.....	9
4 General	10
5 Light flickermeter	11
6 Voltage fluctuation disturbance signal.....	11
6.1 General.....	11
6.2 Mains signal parameters	13
6.3 Disturbance signal parameters and test levels	13
7 Test setup and equipment	15
7.1 General.....	15
7.2 Test voltage	15
7.3 Optical test environment	16
7.4 Light sensor and amplifier	16
7.5 Signals to be measured	16
7.6 Signal processing	17
7.6.1 Anti-aliasing filter.....	17
7.6.2 Sampling frequency	17
7.6.3 Signal resolution.....	18
8 Verification procedure.....	19
8.1 General.....	19
8.2 Light flickermeter	19
8.3 Mains voltage parameters without modulation.....	20
8.3.1 Nominal voltage level	20
8.3.2 Mains frequency	20
8.4 Voltage fluctuation level.....	20
8.4.1 General	20
8.4.2 Option 1: measure the actual modulation frequencies and voltage levels	20
8.4.3 Option 2: measure P_{st}^V -values using a flickermeter	20
8.5 Light sensor and amplifier	21
8.6 Test environment	21
8.7 Light flicker noise.....	21
9 Test procedure	21
10 Conditions during testing	22
11 Evaluation of the test result	22
12 Test report.....	23
Annex A (informative) Specification of the light flickermeter	24
A.1 Voltage flickermeter	24
A.2 Specification of the light flickermeter.....	25
A.2.1 General	25

A.2.2	Block a: illuminance adapter	25
A.2.3	Block b: weighting filters	25
A.2.4	Block c: squaring multiplier, sliding mean filter and scaling	26
A.2.5	Block d: statistical analysis	26
A.3	Verification of the light flickermeter	27
A.4	Example of P_{st}^{LM} implementation in MATLAB®	27
Annex B (informative)	Uncertainty considerations	28
B.1	General.....	28
B.2	General symbols	28
B.3	Measurand.....	28
B.4	Influence quantities.....	28
B.5	Uncertainty budget.....	30
Annex C (informative)	Examples of test results of lighting equipment.....	32
C.1	Test without voltage fluctuations	32
C.2	Test with (intentional) voltage fluctuations	32
C.3	Test under dimming conditions.....	36
Bibliography.....		38
Figure 1 – Full EMC approach for mains voltage fluctuations		11
Figure 2 – Definition of the mains test signal including a rectangular modulated voltage fluctuation (see Equation (1)).....		13
Figure 3 – Block diagram voltage-fluctuation immunity test		15
Figure 4 – Example of a recorded mains voltage fluctuation and illuminance signal of a 60 W incandescent lamp		19
Figure A.1 – Structure of the IEC 61000-4-15 flickermeter which uses voltage as input.....		24
Figure A.2 – Structure of the light flickermeter		24
Figure C.1 – Graphical P_{st}^{LM} results for three EUTs with rectangular modulation at five frequencies ($P_{st}^V = 1$)		33
Figure C.2 – EUT1: recorded signals (no mains voltage modulation).....		34
Figure C.3 – EUT1: recorded signals (with modulation).....		35
Figure C.4 – EUT2: relative illuminance: mains voltage modulation $d = 0,407\%$ at 13,5 Hz ($P_{st}^V = 1$)		36
Figure C.5 – EUT3: relative illuminance: mains voltage modulation $d = 0,407\%$ at 13,5 Hz ($P_{st}^V = 1$)		36
Figure C.6 – Graphical P_{st}^{LM} results for four EUTs under dimming conditions		37
Table 1 – Voltage fluctuations – Test specification of voltage fluctuations applied at input AC power ports 120/230 V; 50/60 Hz.....		14
Table A.1 – Test specification of illuminance fluctuations for lightmeter classifier		27
Table B.1 – Influence quantities and their recommended tolerances		29
Table B.2 – Uncertainty budget of the voltage fluctuation immunity test		31
Table C.1 – Numerical results P_{st}^{LM} calculations for three EUTs without voltage modulation...32		32
Table C.2 – Numerical results P_{st}^{LM} calculations for three EUTs with voltage modulation		32
Table C.3 – Numerical results P_{st} calculations for four EUTs under dimming conditions		37

INTERNATIONAL ELECTROTECHNICAL COMMISSION

EQUIPMENT FOR GENERAL LIGHTING PURPOSES – EMC IMMUNITY REQUIREMENTS–

Part 1: An objective light flickermeter and voltage fluctuation immunity test method

FOREWORD

- 1) The International Electrotechnical Commission (IEC) is a worldwide organization for standardization comprising all national electrotechnical committees (IEC National Committees). The object of IEC is to promote international co-operation on all questions concerning standardization in the electrical and electronic fields. To this end and in addition to other activities, IEC publishes International Standards, Technical Specifications, Technical Reports, Publicly Available Specifications (PAS) and Guides (hereafter referred to as "IEC Publication(s)"). Their preparation is entrusted to technical committees; any IEC National Committee interested in the subject dealt with may participate in this preparatory work. International, governmental and non-governmental organizations liaising with the IEC also participate in this preparation. IEC collaborates closely with the International Organization for Standardization (ISO) in accordance with conditions determined by agreement between the two organizations.
- 2) The formal decisions or agreements of IEC on technical matters express, as nearly as possible, an international consensus of opinion on the relevant subjects since each technical committee has representation from all interested IEC National Committees.
- 3) IEC Publications have the form of recommendations for international use and are accepted by IEC National Committees in that sense. While all reasonable efforts are made to ensure that the technical content of IEC Publications is accurate, IEC cannot be held responsible for the way in which they are used or for any misinterpretation by any end user.
- 4) In order to promote international uniformity, IEC National Committees undertake to apply IEC Publications transparently to the maximum extent possible in their national and regional publications. Any divergence between any IEC Publication and the corresponding national or regional publication shall be clearly indicated in the latter.
- 5) IEC itself does not provide any attestation of conformity. Independent certification bodies provide conformity assessment services and, in some areas, access to IEC marks of conformity. IEC is not responsible for any services carried out by independent certification bodies.
- 6) All users should ensure that they have the latest edition of this publication.
- 7) No liability shall attach to IEC or its directors, employees, servants or agents including individual experts and members of its technical committees and IEC National Committees for any personal injury, property damage or other damage of any nature whatsoever, whether direct or indirect, or for costs (including legal fees) and expenses arising out of the publication, use of, or reliance upon, this IEC Publication or any other IEC Publications.
- 8) Attention is drawn to the Normative references cited in this publication. Use of the referenced publications is indispensable for the correct application of this publication.
- 9) Attention is drawn to the possibility that some of the elements of this IEC Publication may be the subject of patent rights. IEC shall not be held responsible for identifying any or all such patent rights.

The main task of IEC technical committees is to prepare International Standards. However, a technical committee may propose the publication of a Technical Report when it has collected data of a different kind from that which is normally published as an International Standard, for example "state of the art".

IEC TR 61547-1, which is a Technical Report, has been prepared by technical committee 34: Lamps and related equipment.

This second edition cancels and replaces the first edition published in 2015. This edition constitutes a technical revision.

This edition includes the following significant technical changes with respect to the previous edition:

- a) the title of Part 1 has been changed to reflect the more general application of the objective flickermeter;
- b) the specific voltage fluctuation immunity test method has been extended for lighting equipment rated for 120 V AC and 230 V AC, 50 Hz and 60 Hz.

The text of this Technical Report is based on the following documents:

Draft TR	Report on voting
34/387/DTR	34/398A/RVDTR

Full information on the voting for the approval of this Technical Report can be found in the report on voting indicated in the above table.

This document has been drafted in accordance with the ISO/IEC Directives, Part 2.

A list of all parts in the IEC 61547 series, published under the general title *Equipment for general lighting purposes – EMC immunity requirements*, can be found on the IEC website.

The committee has decided that the contents of this document will remain unchanged until the stability date indicated on the IEC website under "<http://webstore.iec.ch>" in the data related to the specific document. At this date, the document will be

- reconfirmed,
- withdrawn,
- replaced by a revised edition, or
- amended.

A bilingual version of this publication may be issued at a later date.

IMPORTANT – The 'colour inside' logo on the cover page of this publication indicates that it contains colours which are considered to be useful for the correct understanding of its contents. Users should therefore print this document using a colour printer.

INTRODUCTION

The fast rate at which solid state light (SSL) sources can change their intensity is one of the main drivers behind the revolution in the lighting world and applications of lighting. Linked to the fast rate of the intensity change is a direct transfer of the modulation of the driving current, both intended and unintended, to a modulation of the luminous output. This light modulation can give rise to changes in the perception of the environment. While in some very specific entertainment, scientific or industrial applications, a change of perception due to light modulation is desired, for most everyday applications and activities the change is detrimental and undesired. The general term used for these changes in the perception of the environment is “temporal light artefacts” (TLAs) and these can have a large influence on the judgment of the light quality. Moreover, the visible modulation of light can lead to a decrease in performance, increased fatigue as well as acute health problems like epileptic seizures and migraine episodes [18][19]¹.

Different terms exist to describe the different types of TLAs that may be perceived by humans. The term ‘flicker’ refers to light variation that may be directly perceived by an observer. ‘Stroboscopic effect’ is an effect which may become visible for an observer when a moving or rotating object is illuminated (CIE TN 006:2016[22]).

Possible causes for light modulation of lighting equipment that may give rise to flicker or stroboscopic effect are:

- AC supply combined with light source technology and its driver topology;
- dimming technology of externally applied dimmers or internal light level regulators;
- mains voltage fluctuations caused by electrical apparatus connected to the mains (conducted electromagnetic disturbances) or intentionally applied for mains-signalling purposes.

Lighting products that show unacceptable flicker or stroboscopic effect are considered as poor quality lighting.

This document provides an objective light flickermeter and a method for testing the immunity of lighting equipment against mains voltage fluctuations caused by electrical apparatus connected to the mains at levels that are allowed through IEC 61000-3-3.

Flicker perception, as well as IEC 61000-3-3 and IEC 61000-4-15, the associated standards for voltage fluctuations and flickermeter, are based on the 60 W incandescent lamp. As a result of the phasing out of incandescent lamps and the widespread introduction of alternative lighting equipment technologies, a new reference lamp was considered. It has been demonstrated that new lighting technologies are in general less but sometimes also more sensitive to supply voltage fluctuations than the current 60 W incandescent lamp. A CIGRE working group has assessed the impact of new lighting technologies on the existing flicker standards [17]. For the moment, the present flicker sensitivity curve of IEC 61000-3-3 remains as the reference. However, because of the increased diversity of sensitivity of lighting equipment to voltage fluctuations, there is a future need for a voltage-fluctuation immunity test specifically for lighting equipment. In this way, the full EMC approach (Figure 1) is introduced for flicker, i.e. with a view to limiting voltage fluctuations caused by equipment connected to the grid, and in addition to establishing a minimum level of flicker immunity of lighting equipment against these voltage fluctuations.

This document will allow the lighting industry to gain experience in flicker immunity test methods. Results of actual tests will be reported in a separate IEC Technical Report. Based on the experience gained on this immunity test method, the adoption of a similar test to be applied for IEC 61547, the immunity standard for lighting equipment, will be considered.

¹ Numbers in square brackets refer to the Bibliography.

EQUIPMENT FOR GENERAL LIGHTING PURPOSES – EMC IMMUNITY REQUIREMENTS –

Part 1: An objective light flickermeter and voltage fluctuation immunity test method

1 Scope

This part of IEC 61547 describes an objective light flickermeter, which can be applied for, amongst others, the following purposes:

- testing the intrinsic performance of all lighting equipment without voltage fluctuations;
- testing the immunity performance of lighting equipment against (unintentional) voltage fluctuation disturbance on the AC power port;
- testing the immunity performance of lighting equipment against intentional voltage fluctuation on the AC power port arising for example from ripple control systems.

The object of this document is to establish a common and objective reference for evaluating the performance of lighting equipment in terms of illuminance flicker. Temporal changes in the colour of light (chromatic flicker) are not considered in this test.

This method can be applied to lighting equipment which is within the scope of IEC technical committee 34, such as lamps and luminaires, intended for connection to a low voltage electricity supply. Independent auxiliaries such as drivers can also be tested by application of a representative light source to that auxiliary.

The objective light flickermeter and voltage fluctuation immunity method described in this document are based on the IEC 61000-3-3 standard for voltage fluctuation limits and the flickermeter standard IEC 61000-4-15.

The objective light flickermeter described in this document can be applied to objectively assess flicker of lighting equipment that is powered from any type of source, AC mains, DC mains, battery fed or fed through an external dimmer. The specific voltage fluctuation immunity test method described in this document applies to lighting equipment rated for 120 V AC and 230 V AC, 50 Hz and 60 Hz.

NOTE The principle of the method can be applied for other nominal voltage and frequency ratings.

2 Normative references

The following documents are referred to in the text in such a way that some or all of their content constitutes requirements of this document. For dated references, only the edition cited applies. For undated references, the latest edition of the referenced document (including any amendments) applies.

IEC 61000-3-3:2013, *Electromagnetic compatibility (EMC) – Part 3-3: Limits – Limitation of voltage changes, voltage fluctuations and flicker in public low-voltage supply systems, for equipment with rated current ≤ 16 A per phase and not subject to conditional connection*

IEC 61000-4-15:2010, *Electromagnetic compatibility (EMC) – Part 4-15: Testing and measurement techniques – Flickermeter – Functional and design specifications*

3 Terms, definitions, abbreviated terms and symbols

3.1 Terms and definitions

For the purposes of this document, the terms and definitions given in IEC 61000-3-3 and IEC 61000-4-15 and the following apply.

ISO and IEC maintain terminological databases for use in standardization at the following addresses:

- IEC Electropedia: available at <http://www.electropedia.org/>
- ISO Online browsing platform: available at <http://www.iso.org/obp>

3.1.1 flicker

impression of unsteadiness of visual sensation induced by a light stimulus whose luminance or spectral distribution fluctuates with time

[SOURCE: IEC 60050-845:1987, 845-02-49]

3.1.2 flickermeter

instrument designed to measure any quantity representative of flicker

[SOURCE: IEC 60050-614:2016, 614-01-30]

3.1.3 voltage flickermeter

instrument as specified in IEC 61000-4-15 which is designed to measure any quantity representative of flicker resulting from mains voltage fluctuations

3.1.4 illuminance

quotient of the luminous flux $d\Phi_v$ incident on an element of the surface containing the point, by the area dA of that element

Equivalent definition. Integral, taken over the hemisphere visible from the given point, of the expression $L_v \cdot \cos \theta \cdot d\Omega$ where L_v is the luminance at the given point in the various directions of the incident elementary beams of solid angle $d\Omega$, and θ is the angle between any of these beams and the normal to the surface at the given point

$$E_v = \frac{d\Phi_v}{dA} = \int_{2\pi \text{ sr}} L_v \cdot \cos \theta \cdot d\Omega$$

Note 1 to entry: Illuminance is expressed in lx or $\text{lm} \cdot \text{m}^{-2}$

[SOURCE: IEC 60050-845:1987, 845-01-38]

3.1.5 light flickermeter

instrument designed to measure flicker resulting from temporal changes in the intensity of the light in an objective way and based on the IEC 61000-4-15 specifications

3.1.6 threshold of flicker irritability

maximum value of a fluctuation of luminance or of spectral distribution which gives rise to a flicker tolerated without discomfort by a specified sample of the population

[SOURCE: IEC 60050-161:1990, 161-08-16]

3.1.7 short-term flicker indicator

P_{st}
measure of flicker evaluated over a specified time interval of a relatively short duration

Note 1 to entry: The duration is typically 10 min, in accordance with IEC 61000-4-15.

Note 2 to entry: The alternative term "short term flicker severity" is used in IEC 61000-3-3 and IEC 61000-4-15.

[SOURCE: IEC 60050-161:1990, 161-08-18, modified — Note 2 has been added.]

3.2 Abbreviated terms

AC	alternating current
AM	amplitude modulation
CFL	compact fluorescent lamp
CIE	Commission Internationale de l'Éclairage
cpm	changes per minute
DC	direct current
EUT	equipment under test
EMC	electromagnetic compatibility
EMI	electromagnetic interference
Hz	hertz
IEEE	Institute of Electrical and Electronics Engineers
kHz	kilohertz
LED	light emitting diode
LP	low pass
ms	millisecond
rect	rectangular
RMS	root mean square
SSL	solid state lighting
TLAs	temporal light artefacts
V	voltage
W	watt

3.3 Symbols

α	multiplication factor
C_A	gain of the light amplifier
d	relative voltage change
d_E	relative change of the rectangular modulation of the illuminance
d_r	relative change of the 100 Hz-illuminance ripple
Δu	instantaneous total voltage variation after a voltage fluctuation
ΔU	total voltage variation of the half-period RMS value after a voltage fluctuation
f	mains frequency (50 Hz)
f_m	modulation frequency
m	modulation index

%	percent
pp	percentage point
P_{inst}	instantaneous flicker sensation
P_{st}	short-term flicker indicator
P_{st}^E	P_{st} -value of the standardized illuminance waveform $E(t)$
P_{st}^{EUT}	P_{st} -value of the illuminance of an EUT measured with a light flickermeter
P_{st}^{LM}	flicker metric of the illuminance measured with a light flickermeter
P_{st}^V	flicker metric of the supply voltage measured with a voltage flickermeter
$P_{st}^{LM} _{noise}$	light flicker noise level
$P_{st}^V _{noise}$	mains flicker noise level
s	complex Laplace variable
\hat{u}	amplitude of the mains voltage
$u(t)$	mains voltage signal
$u_E(t)$	output voltage of the light sensor amplifier
T_m	modulation period
T_{test}	period of time over which the illuminance is measured during application of the voltage fluctuation
U	half-period RMS value

4 General

The immunity of lighting equipment to voltage fluctuations may be tested by applying specific types and levels of voltage fluctuations to the mains, in accordance with the short-term flicker indicator $P_{st} = 1$ curve for the reference incandescent lamp of 60 W specified in IEC 61000-3-3. In this way, the full EMC approach is applied for flicker, i.e. voltage fluctuations caused by equipment connected to the grid are limited by the voltage fluctuation emission test of IEC 61000-3-3, while the level of flicker immunity of lighting equipment against these $P_{st} = 1$ voltage fluctuations is tested using the method specified in this document (see Figure 1).

During the test, the supply voltage is modulated with $P_{st} = 1$ fluctuation (denoted as P_{st}^V) extracted from the threshold of the flicker irritability curve and the luminous intensity variation of the lighting equipment is measured and recorded. A light flickermeter is applied to measure the value of the metric P_{st} (denoted as P_{st}^{LM}).

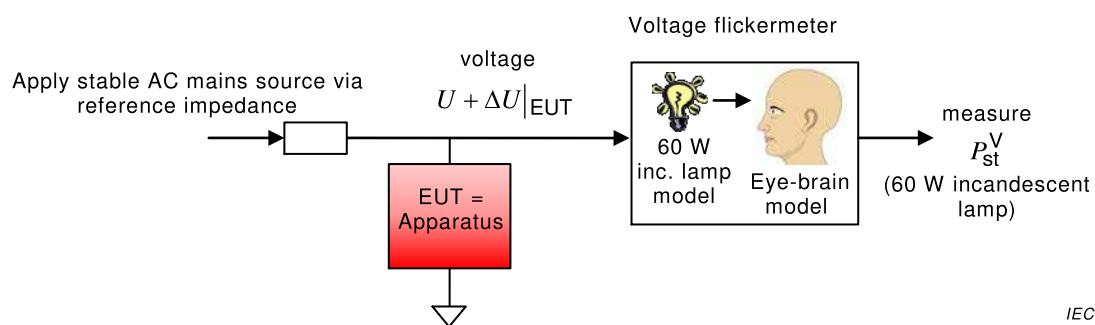

a) Voltage fluctuation emission test in IEC 61000-3-3, using the IEC voltage flickermeter in IEC 61000-4-15

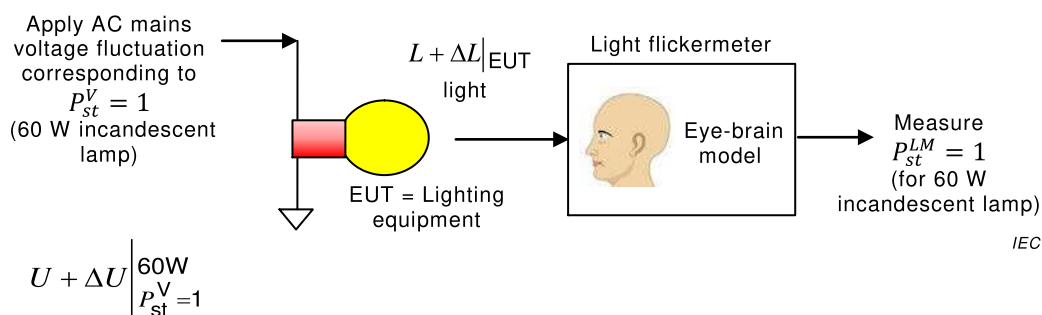

b) Voltage fluctuation immunity test specified in this document

Figure 1 – Full EMC approach for mains voltage fluctuations

5 Light flickermeter

For objective assessment of flicker due to low-frequency light modulation, the flickermeter specified in Annex A is used. Additional requirements for the light flickermeter are given in 7.3, 7.4, 7.5 and 7.6.

This light flickermeter can be applied to objectively assess the flicker of lighting equipment that is powered from any type of source, AC mains, DC mains, battery powered or powered through an external dimmer. In this document, specific mains voltage disturbance signals are given in Clause 6 for 120 V AC and 230 V AC, 50 Hz and 60 Hz networks.

6 Voltage fluctuation disturbance signal

6.1 General

The immunity test against voltage fluctuations is carried out in accordance with the test method specified in Clause 7. The disturbances are rectangular amplitude modulations that are to be applied on the AC power port.

The mains signal is to be amplitude modulated with rectangular signals with frequencies between approximately 0,05 Hz and 40 Hz. For the rectangular modulated mains signal $u(t)$, the following Equation (1) applies:

$$u(t) = \hat{u} \cdot \sin(2\pi ft) \cdot \{1 + m \cdot \text{signum}(\sin(2\pi f_m t))\} \quad (1)$$

where

\hat{u} is the amplitude of the mains voltage;

f is the mains frequency (50 Hz);

m is the modulation index;

signum(x) = the signum function, $\text{signum}(x) = 1$ for $x > 0$
 $\text{signum}(x) = 0$ for $x = 0$
 $\text{signum}(x) = -1$ for $x < 0$

f_m is the modulation frequency = $1/T_m$.

Furthermore the half-period RMS value U of the unmodulated mains signal can be written as:

$$U = \hat{u} / \sqrt{2} \quad (2)$$

In IEC 61000-4-15, the parameter d is applied, which is the total relative voltage change:

$$d = \Delta u / \hat{u} = \Delta U / U, \quad (3)$$

for rectangular AM modulation with modulation frequencies $< f$

where

Δu is the instantaneous total voltage variation after a voltage fluctuation;

ΔU is the total voltage variation of the half-period RMS value after a voltage fluctuation.

For a rectangular modulated mains signal with modulation index m the relative voltage change d is:

$$d = 2m. \quad (4)$$

The relative voltage change (or voltage fluctuation) d is often expressed as a percentage.

An example of the parameters is shown in Figure 2.

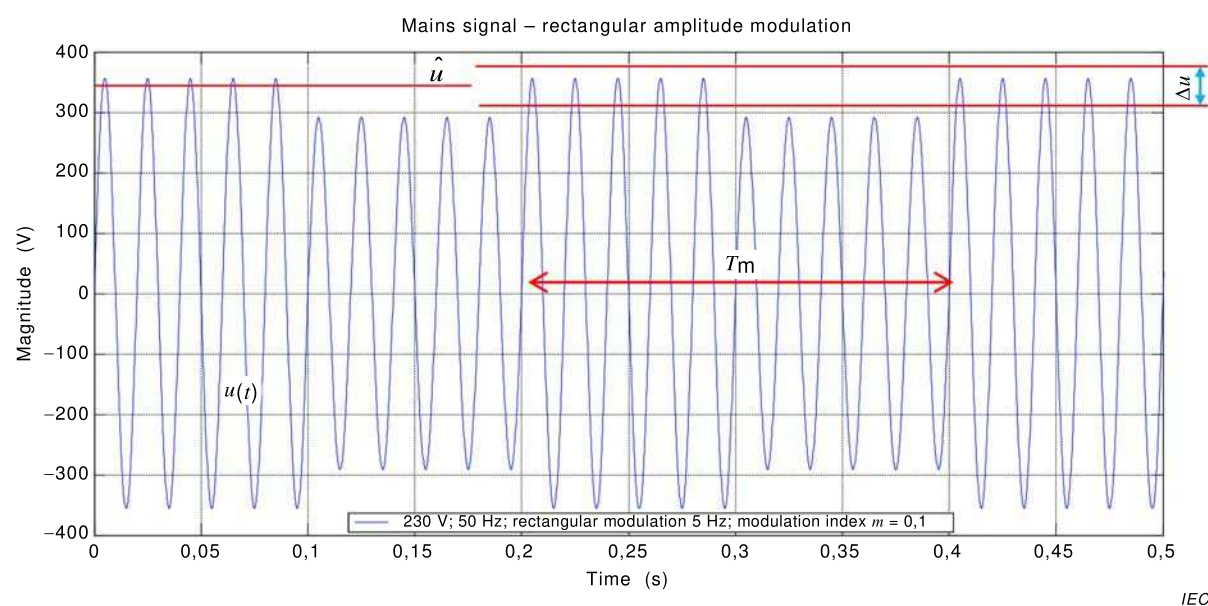

EXAMPLE Amplitude modulated mains signal (230 V; 50 Hz). Rectangular modulation; frequency 5 Hz (600 cpm); $T_m = 0,2$ s; modulation index $m = 0,1$ (relative voltage change $d = 20$ %).

Figure 2 – Definition of the mains test signal including a rectangular modulated voltage fluctuation (see Equation (1))

Voltage fluctuations frequencies are often expressed in terms of voltage changes per minute (cpm). The relation between the voltage fluctuation frequency f_m (in Hz) and the cpm (one cycle contains two changes) is:

$$f_m = \text{cpm} / 120. \quad (5)$$

6.2 Mains signal parameters

The unmodulated test voltage level U should be set and maintained at the nominal value of 120 V or 230 V, with a tolerance of $\pm 0,5$ %.

The mains frequency f should be set and maintained with a tolerance of $\pm 0,5$ % of the nominal value of 50 Hz or 60 Hz.

Residual fluctuations of the unmodulated test supply voltage during a test may give rise to P_{st}^V that are not exactly zero. It is recommended to keep this P_{st}^V -noise level below 0,2. See Clause B.5 for the impact on the uncertainty of the test.

NOTE In IEC 61000-3-3, the P_{st}^V -noise level is specified to be less than 0,4 which can induce an uncertainty of 8 % in the IEC 61000-4-15 measurement. However, in this test protocol, there are many sources of uncertainty and that is the reason to set a more strict P_{st}^V -noise level tolerance.

6.3 Disturbance signal parameters and test levels

Specific test frequencies and types of modulation are specified in the IEC flickermeter standard IEC 61000-4-15 for performance verification purposes. It is recommended to also use the test frequencies and the rectangular modulation given in IEC 61000-4-15:2010, Table 5 as test signals for voltage fluctuation immunity testing of lighting equipment.

The recommended specific levels of relative voltage changes and modulation frequencies to be applied are given in Table 1. The test levels in this table are partly taken from the flickermeter performance test specifications given in IEC 61000-4-15:2010, Table 5, and from

the test level at 8,8 Hz given in IEC 61000-4-15:2010, Table 2b. The latter frequency is the most sensitive frequency over the frequency range of interest.

The rectangular modulation pattern should be applied with a duty cycle of $50 \% \pm 2$ percentage point (pp), and the transition time from one voltage level to the next should be less than 0,5 ms. All test frequency and level combinations will give a short-term flicker value of $P_{st}^V = 1$ corresponding to the threshold of the flicker irritability curve.

The duration of the voltage fluctuation applied to the EUT should be minimally 180 s (see footnote c of Table 1).

Table 1 – Voltage fluctuations – Test specification of voltage fluctuations applied at input AC power ports 120/230 V; 50/60 Hz

Rectangular amplitude modulations with duty cycle of 50 % ^{a c d}					
Voltage changes per minute cpm	Modulation frequency f_m Hz	Relative voltage fluctuation $d = \Delta U/U$ %			
		120 V 50 Hz	120 V 60 Hz	230 V 50 Hz	230 V 60 Hz
39	0,325 0	1,045	1,040	0,894	0,895
110	0,916 7	0,844	0,844	0,722	0,723
1 056	8,8	0,353 ^b	0,353 ^b	0,275 ^b	0,275 ^b
1 620	13,5	0,545	0,548	0,407	0,409
4 000	33 1/3 ^e	3,426	Test not required	2,343	Test not required
4 800	40,0 ^e	Test not required	4,837	Test not required	3,263

^a See Table 5 of IEC 61000-4-15:2010.

^b See Tables 2a and 2b of IEC 61000-4-15:2010 for $P_{inst} = 1$; the values of $d = 0,252 \%$ and $d = 0,196 \%$ are increased to respectively $0,353 \%$ and $0,275 \%$ to give $P_{st} = 1$.

^c The duration of the voltage fluctuation and recording of the illuminance is recommended to be minimally 180 s (60 s for the transient response of the flickermeter's filters and 120 s for the duration of the statistical evaluation of the flicker level in block d, see A.2.5). First of all, the transient response of the light flickermeter's filters shall be considered, which is dominated by the illuminance adapter (block a, see A.2.2). The time constant of this filter is set at 10 s, reaching the 90 % of the value corresponding to the steady state response at approximately 50 s. In addition, the evaluation period should contain an integer number of voltage fluctuation periods. For the set of test modulation frequencies given in this table, the minimum duration to achieve an integer number of voltage fluctuation periods in all the test cases is 120 s.

^d Recommended absolute tolerance for the duty cycle is ± 2 pp, for the modulation frequency the recommended tolerance is $\pm 1 \%$ and for the relative voltage fluctuation the recommended tolerance is $\pm 5 \%$.

^e The 33 1/3 Hz and 40 Hz modulation frequencies should be synchronous with the supply frequency of respectively 50 Hz and 60 Hz with a fixed phase angle as defined by Equation (1).

^f The light flicker specifications in this document are expanded such that it is aligned with the voltage flicker specifications given in IEC 61000-4-15, which is limited to 120 V and 230 V, 50 Hz and 60 Hz. No voltage fluctuation tests are yet available for 100 V, 200 V and 277 V. However, in practice, the test specifications given in this table for 120 V and 230 V can be applied for 100 V and 200/277 V respectively for indicative purposes.

7 Test setup and equipment

7.1 General

The block diagram of the test setup is shown in Figure 3. One can distinguish three parts in the setup:

- generation of the test voltage,
- application of the test voltage to the EUT, photometric measurement of the EUT in an optically shielded environment,
- measurement and control equipment.

More details of the equipment properties are described below.

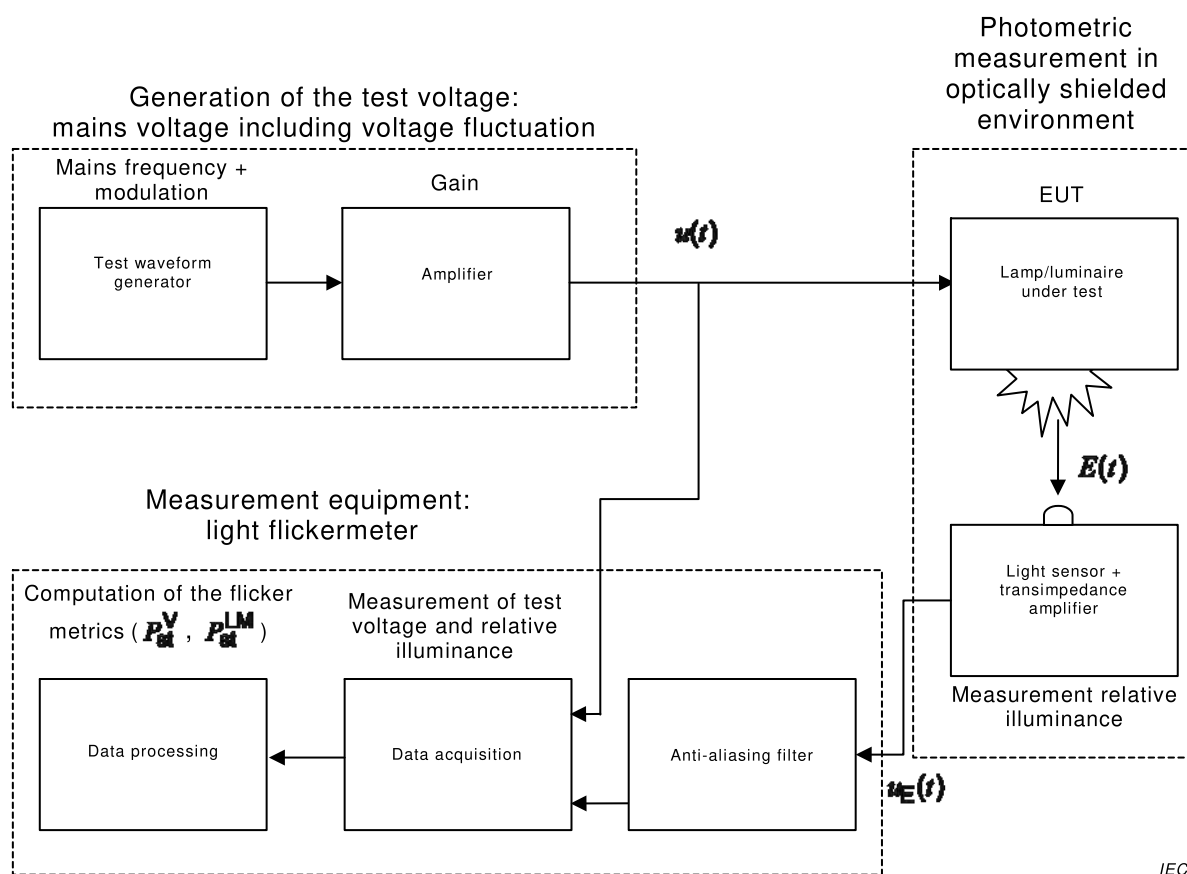

Figure 3 – Block diagram voltage-fluctuation immunity test

7.2 Test voltage

The test voltage, which consists of the mains voltage with a rectangular amplitude modulation, can be synthesized using a waveform generator and an amplifier. This may be implemented also by using a separate waveform generator for the modulating signal that is applied to a generator that makes the 50/60 Hz mains signal.

It is important that the equipment for generating the amplitude modulation is capable of generating voltage fluctuations well below the lowest test level of $d = 0,275\%$ at 8,8 Hz (see Table 1).

Care should be taken that no other disturbing signals than the amplitude modulation are present (see 6.2 and 8.4 for the verification).

The characteristics of the test voltage should be verified by either measurement through an oscilloscope or by direct application of an IEC 61000-4-15 flickermeter (see 8.3).

7.3 Optical test environment

The illuminance of the EUT is to be measured for processing by the light flickermeter. There is no need for measuring the absolute value. Only the relative illuminance is to be determined.

The EUT and the light sensor are to be located in an optically shielded environment to avoid disturbances from light sources other than the EUT.

The test environment should be also mechanically robust to avoid vibrations of the EUT and light sensor that may give rise to unwanted variations in the illuminance.

It is recommended that the light output of the EUT is measured indirectly via a reflecting surface. This is especially true for lighting equipment with a spatial distribution of light sources (e.g. TL, TLED, 2D LED matrix).

An integrating sphere, like an Ulbricht sphere, may be applied. This may be convenient because then the orientation and alignment of the EUT with respect to the light sensor is less critical.

7.4 Light sensor and amplifier

A photodiode with a filter and an appropriate amplifier is to be applied for measuring the illuminance (or more specific: the relative illuminance) of the EUT.

The photodiode, optical filter and amplifier combination should satisfy the following characteristics:

- a) the optical filter should match the photodiode to the eye sensitivity curve of CIE 1931 which is the CIE 1931 standard observer function specified in ISO 11664-1:2007 [3];
- b) the cut-off frequency of the amplifier should enable measurement of all flicker-relevant frequencies. A cut-off frequency of 2 kHz is recommended;
- c) the output voltage of the amplifier should vary linearly with the illuminance and no offset-voltage should be present.

7.5 Signals to be measured

The output voltage $u_E(t)$ of the light sensor amplifier is measured as a function of time over a period T_{test} . The output voltage $u_E(t)$ varies linearly with the illuminance $E(t)$:

$$u_E(t) = C_A \cdot E(t) \text{ is measured between } 0 < t < T_{\text{test}} \quad (6)$$

where C_A is the constant including the gain of the amplifier and which relates the output voltage of the light sensor amplifier to the illuminance.

In addition, the mains voltage including the voltage variation $u(t)$ is measured over the same time period.

The signals can be measured with an oscilloscope. It is recommended to apply an appropriate low-pass filter in the oscilloscope to limit the noise.

The measured signals are to be recorded for further processing.

7.6 Signal processing

7.6.1 Anti-aliasing filter

The light output of some types of lamps may contain spectral components at frequencies well above 100 Hz (kHz-range) that are not producing visible flicker. Depending on the sampling frequency (see 7.6.2) these higher frequency components may be undersampled and this may lead to aliasing which gives artefacts in the light sensor signal. It is recommended to avoid such aliasing effects by application of a low-pass filter between the amplifier output of the light sensor and the measurement system.

EXAMPLE A 1st order low-pass filter with 3 dB cut-off frequency of 1 kHz will attenuate a factor 10 at 3 kHz. For 3 kHz, the sampling frequency is then at least 6 kHz.

7.6.2 Sampling frequency

For processing of the signals, in accordance with the Nyquist criterion, the sampling frequency shall be at least twice the bandwidth of the signal, which is approximately twice the highest frequency within the signal to be measured.

The mains voltage signal of 50/60 Hz with amplitude modulation ranging from 0,5 Hz up to 40 Hz has a spectrum of interest up to the sum of the mains and the modulation frequency. Hence, the frequency range of interest of the mains voltage signal extends roughly up to 100 Hz.

The illuminance signal has a spectrum of interest that is at least twice the spectrum of the mains signal for incandescent lamps. For non-incandescent type of lighting equipment, much higher frequencies may be present depending on the driver technology applied. As these much higher frequencies are not of interest for flicker, these should be filtered before sampling (see 7.6.1).

Interharmonics may also cause beat frequencies that may produce light flicker.

Still for calculating flicker, the highest frequency of interest is determined by the highest modulation frequency, the mains frequency and the possible interharmonics. The flickermeter, and also the light flickermeter contain a bandpass filter (0,05 Hz to 35 Hz), see Annex A.

Although the highest frequency of interest in the illuminance signal is limited to approximately 200 Hz, the way the various digital filters are implemented usually requires oversampling and therefore much higher sampling rates (see [9][12]).

For the MATLAB^{®2} implementation of the IEC 614000-4-15 flickermeter given in [14] a sampling rate of at least 2 kHz is recommended. Therefore, for the light flickermeter a sampling rate of at least 4 kHz is recommended as the bandwidth of the illuminance signal resulting from the mains voltage and its fluctuations is approximately twice the bandwidth of the mains signal. As explained in 7.6.1, the sampling frequency shall be selected also in conjunction with the cut-off frequency of the anti-aliasing filter applied. For practical low-pass filters with a cut-off frequency around 1 kHz, a sample rate of at least 10 kHz is recommended.

An example of a recorded illuminance signal over a period of 1 s is given in Figure 4. The 100 Hz ripple, which is typical for an incandescent lamp, and the additional modulation resulting from the amplitude modulation of the mains voltage at 8,8 Hz ($d = 0,275\%$) are clearly visible.

² MATLAB is the trademark of a product supplied by The MathWorks, Inc. This information is given for the convenience of users of this document and does not constitute an endorsement by IEC of the product named.

7.6.3 Signal resolution

As a result of the recommended P_{st}^V -noise level of 0,2 (see 6.2), the uncertainty of the relative voltage fluctuation should be 0,2 times the lowest level of the relative voltage fluctuation, which is 0,2 % at 8,8 Hz amplitude modulation. Hence the uncertainty of the relative voltage fluctuation should be less than 0,055 % (-65 dB). This means that in the case of application of an AD (analogue to digital) convertor, more than 10 bits is required (signal-to-quantization-noise ratio for 11 bits = -66 dB).

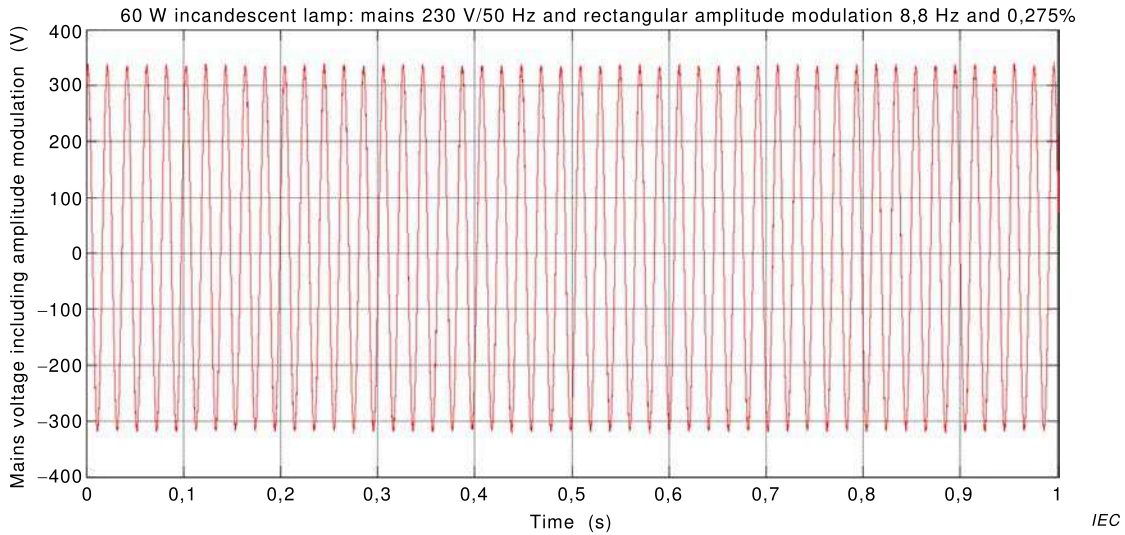

a) Mains voltage fluctuation with rectangular modulation of 8,8 Hz and $d = 0,275\%$

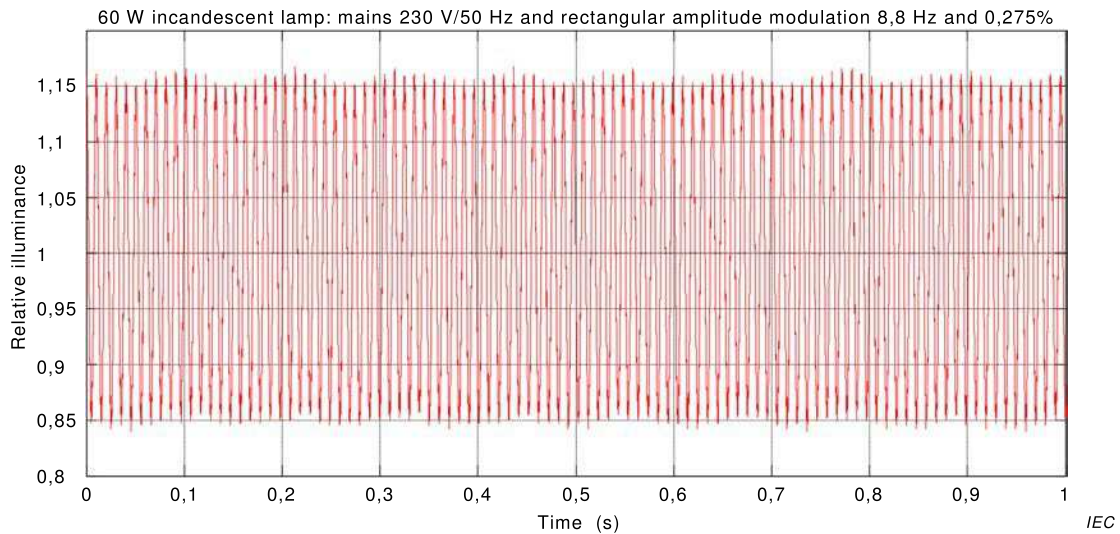

b) Illuminance signal of a 60 W incandescent lamp including a 100 Hz ripple and an additional modulation due to the modulated mains voltage fluctuation (a)

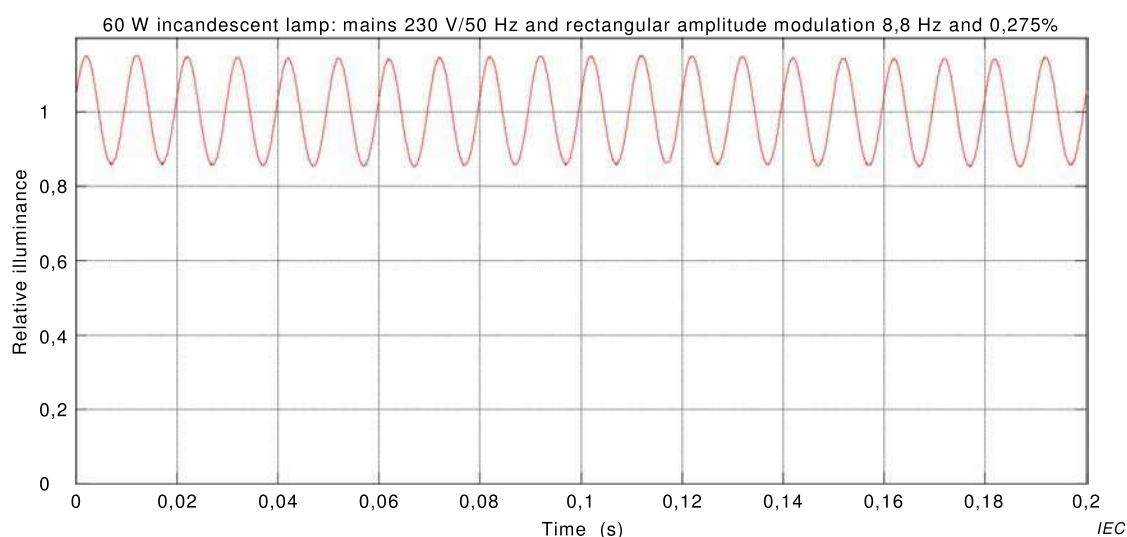

c) Same as b) zoomed over 0,2 s and vertical range from 0 to 1,2

Figure 4 – Example of a recorded mains voltage fluctuation and illuminance signal of a 60 W incandescent lamp

8 Verification procedure

8.1 General

The test is subject to uncertainties. Annex B gives an overview of the main influence quantities for the uncertainty.

In order to limit uncertainties of the test, it is recommended to perform a number of verification tests at regular intervals.

The verifications tests are described in the following subclauses.

8.2 Light flickermeter

Verification of the light flickermeter may be performed using the procedure given in Clause A.3.

It is recommended that the outcome of the verification satisfies the following for all test frequencies given in Table A.1:

$$\left| P_{st}^E - P_{st}^{LM} \right| / P_{st}^E \times 100 \% < 5 \% \quad (7)$$

where

P_{st}^E is the flicker severity value of the standardized illuminance waveform $E(t)$ applied; see Equation (A.7), and

P_{st}^{LM} is the value measured at the output of the light flickermeter using

$$P_{st}^E = \alpha, \quad (8)$$

for $\alpha = 1/4, 1/2, 1, 2, 3, 4$ and 5

where α is the fixed multiplication factor with which all the d_E values given in Table A.1 have to be multiplied.

8.3 Mains voltage parameters without modulation

8.3.1 Nominal voltage level

The RMS-level of the mains signal should be measured when no modulation is applied.

It is recommended that the RMS value satisfies:

$$U [\text{RMS}] = (120 \pm 0,5 \%) \text{ V or } (230 \pm 0,5 \%) \text{ V} \quad (9)$$

8.3.2 Mains frequency

Verify that the mains frequency f satisfies the following:

$$f = (50 \pm 0,5 \%) \text{ Hz or } (60 \pm 0,5 \%) \text{ Hz}, \quad (10)$$

8.4 Voltage fluctuation level

8.4.1 General

It is important to verify the level of the voltage fluctuation when a certain modulation is applied. Two options can be used for this verification.

8.4.2 Option 1: measure the actual modulation frequencies and voltage levels

Verify that the modulation frequencies f_m given in Table 1 satisfy the following:

f_m is within $\pm 1 \%$ of the nominal values given in Table 1.

Apply a 1 % rectangular modulation at a frequency of 2 Hz. Measure the overall change of the peak value of the mains voltage at a transition. This voltage change should be (see Table 1):

$$\Delta u = (120 \times 1 \%) \text{ V} \times \sqrt{2} = (1,70 \pm 2 \%) \text{ V or} \quad (11)$$

$$\Delta u = (230 \times 1 \%) \text{ V} \times \sqrt{2} = (3,25 \pm 2 \%) \text{ V}$$

8.4.3 Option 2: measure P_{st}^V -values using a flickermeter

A flickermeter can be applied for verification of the voltage fluctuation levels as follows.

Measure the flicker noise level of the mains ($P_{\text{st}}^V|_{\text{noise}}$) using the flickermeter, when no modulation is applied. Verify that (see 6.2)

$$P_{\text{st}}^V|_{\text{noise}} < 0,2 \quad (12)$$

Apply rectangular amplitude modulations to the mains in accordance with the specified test levels given in Table 1. Measure the actual flicker level using the flickermeter (P_{st}^V) and verify whether the mains signal including the voltage variation satisfies the following (see Table 1):

$$P_{st}^V = (1 \pm 5) \% \quad (13)$$

8.5 Light sensor and amplifier

Verify the absence of an offset voltage by covering the light sensor such that no light can enter the photodiode. Verify that voltage at the output of the amplifier is less than 0,1 % of the maximum voltage level of the amplifier (within its operating range).

Verify the linearity of the sensor by positioning the photodiode at different distances from a stable small light source in an optical chamber. The voltage should vary linearly with $1/r^2$.

Verify the clipping level of the voltage output of the amplifier, and make sure that tests are executed below this level.

8.6 Test environment

Install the light sensor in the test environment where no EUT is present or in operation. Close the optical test environment and put all (other than the EUT) test equipment into operation.

Verify the absence of electromagnetic disturbances and/or unwanted light ingress in the optical test environment by checking the voltage signal at the output of the amplifier.

Electrical shielding of light sensor and amplifier is highly recommended.

8.7 Light flicker noise

In theory, if the illuminance from the EUT were constant, then $P_{st}^{LM} = 0$. In practice however, the light sensor and its amplifier and the light flickermeter may give a non-zero result if the illuminance is constant. This is called the light flicker noise level $P_{st}^{LM}|_{noise}$. It should be noted that this noise level differs from the noise $P_{st}^V|_{noise}$ due to residual voltage variations of the test signal (see 6.2 and 8.4.3).

The light flicker noise level $P_{st}^{LM}|_{noise}$ can be verified as follows.

Install a suitable AC-fed light source, either an incandescent or halogen lamp. Feed the lamp with a constant voltage without modulation.

Measure the illuminance and determine the actual P_{st} -level using the light flickermeter and verify whether the actual level satisfies the following:

$$P_{st}^{LM}|_{noise} < 0,1 \quad (14)$$

9 Test procedure

The following procedure for execution of a test is recommended:

- a) mount the EUT in the optically shielded enclosure;
- b) switch on the EUT and apply sufficient stabilization time;
- c) if the EUT has a light regulation function, then the light output should be set at 50 % of the maximum light output (see Clause 10 for details);

- d) apply the recommended settings for the data acquisition (duration test, sample rate, filtering);
- e) set the test voltage in accordance with the recommended values of Table 1 ($P_{st}^V = 1$);
- f) measure the P_{st}^{LM} levels of relative illuminance waveform.

An example of a test of a 7 W LED lamp is given in Annex C.

10 Conditions during testing

The EUT should be tested within its intended operating and climatic conditions.

An appropriate stabilization time should be applied for the EUT before execution of the test. The specification of the EUT or the type of technology may indicate the typical stabilization time required.

The EUT should be operated as follows.

- The test should be applied while the EUT is operated as intended under normal operating conditions as laid down in the relevant product standard at stabilized luminous flux and at normal laboratory conditions.
- Testing is recommended at one combination of supply voltage and frequency, as specified by the manufacturer.
- An EUT including a light-regulating control should be tested at a light output level of 50 % \pm 10 % of the maximum light output. If a light output level of 50 % is not available for the EUT including a light regulation function (in case of discrete steps), the test shall be done at the level which is closest to 50 %. If two steps equally distant to 50 % are available, the lower level (< 50 % shall be used for the test (see IEC 61547:2009/ISH1:2013[2] [1]).
- Luminaires and independent auxiliaries should be tested with light sources for which they are intended. Where such equipment can operate with light sources of different wattages, a light source of minimum wattage is recommended.
- If light sources can operate at different colours, select the colour that gives the maximum light output (modulation off).

11 Evaluation of the test result

The P_{st}^{LM} -level that is measured by the light flickermeter will generally differ from the $P_{st}^V = 1$ test level that has been applied through the mains signal and the voltage fluctuation.

The results can be interpreted as follows.

$P_{st}^{EUT} = 1$, the EUT is observed to have equal flicker behaviour as a 60 W incandescent lamp by an average observer, i.e. in 50 % of the cases flicker is observed and in 50 % of the cases no flicker is observed.

$P_{st}^{EUT} < 1$, the EUT is observed to have a better flicker behaviour than a 60 W incandescent lamp by an average observer.

$P_{st}^{EUT} > 1$, the EUT is observed to have a worse flicker behaviour than a 60 W incandescent lamp by an average observer.

12 Test report

The test report should contain all the information necessary to reproduce the test. In particular, it is advised to record the following information:

- a) identification of the EUT and any associated equipment, for example brand name, product type, serial number;
- b) the relevant operating conditions of the EUT (light output level);
- c) the types of interconnecting cables, including their length, and the interface port of the EUT to which they were connected;
- d) any specific conditions for use, for example cable length or type, shielding or grounding, or EUT operating conditions, which are essential for voltage-fluctuation immunity performance;
- e) the warming-up time of the EUT if applicable;
- f) identification of the test equipment, for example brand name, product type, serial number;
- g) any specific conditions necessary to enable the test to be performed;
- h) the nominal mains test frequency and voltage applied;
- i) the applied disturbance signals (modulation frequencies, relative modulation levels);
- j) the duration of the test for each disturbance signal;
- k) the acceptance criteria that have been applied (P_{st}^{LM} -levels).

Annex A (informative)

Specification of the light flickermeter

A.1 Voltage flickermeter

The voltage fluctuation immunity test of the EUT during the test is done in an objective way by using the same P_{st} flicker metric of the voltage-based flickermeter specified in IEC 61000-4-15. This is done by measuring the illuminance variation of the EUT and applying it to an adapted flickermeter which uses illuminance as input instead of the voltage (see Figure 1). Illuminance flickermeters or light flickermeters are described in various papers [4][6][7]. The modification can be implemented by skipping the parts of the incandescent lamp model inside the current flickermeter (Figure A.1).

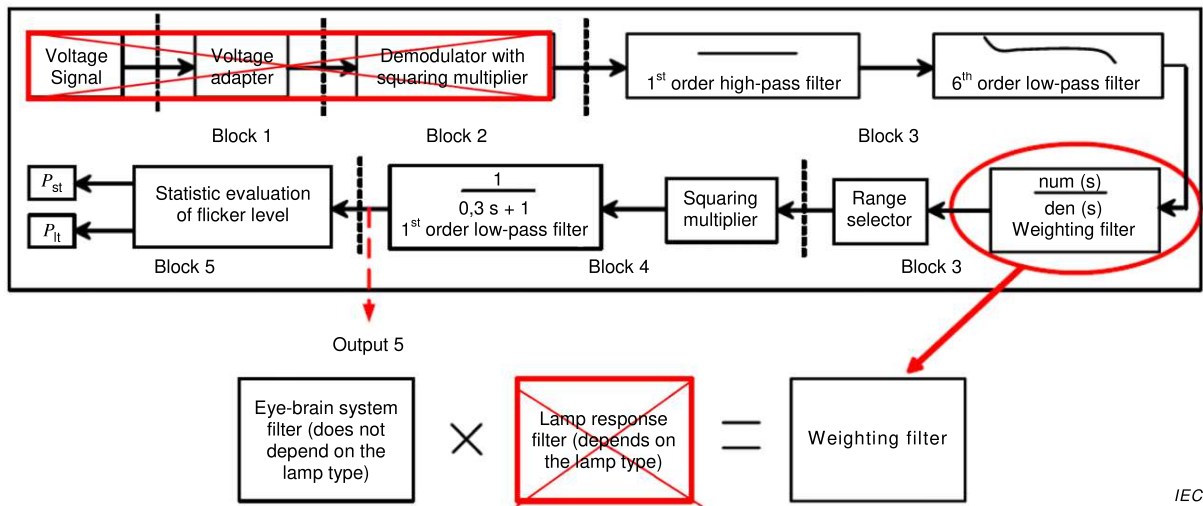

Red blocks indicate the incandescent-lamp specific blocks.

Figure A.1 – Structure of the IEC 61000-4-15 flickermeter which uses voltage as input

This means that the first two blocks of the standardized flickermeter are not applied and part of the third block is also omitted (see Figure A.1). The papers [4][6][7] describe in detail how to 'delete' the lamp response properties from the flickermeter.

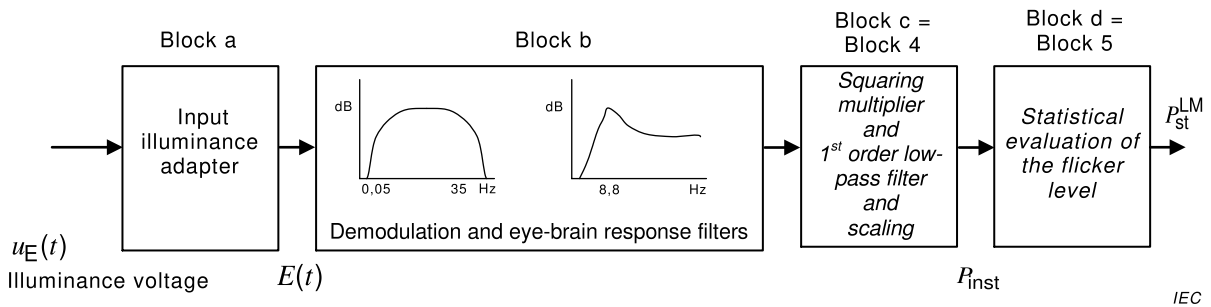

Figure A.2 – Structure of the light flickermeter

A.2 Specification of the light flickermeter

A.2.1 General

The various blocks of the light flickermeter depicted in Figure A.2 are specified in detail in Section 2.2 of [7]. More details on the functions of the blocks a to d are given in Clause A.2.

A.2.2 Block a: illuminance adapter

This block contains an illuminance adapting circuit that scales the voltage $u_E(t)$ that is proportional to the illuminance to the DC value:

$$E(t) = \frac{u_E(t)}{\text{mean}(u_E(t))} \quad (\text{A.1})$$

The DC value can be obtained using a 1st order low-pass filter transfer function with frequency response as follows:

$$F_{\text{LPSC}}(s) = \frac{1}{\tau_{\text{LPSC}} \cdot s + 1} \quad (\text{A.2})$$

where

s is the complex Laplace variable, and

τ_{LPSC} is the filter time constant set at 10 s.

The corresponding filter cut-off frequency is 0,016 Hz.

Applying the signal normalization makes the flicker perception independent of the illuminance level.

A.2.3 Block b: weighting filters

The first part of block b is identical to the first part of block 3 of the flickermeter. This first part includes a 1st order high-pass filter with a 3 dB cut-off frequency of 0,05 Hz and a 6th order low-pass (Butterworth) filter with a 3 dB cut-off frequency of 35 Hz for 230 V/50 Hz systems. See IEC 61000-4-15:2010, 5.4.

The second part of block b is an eye-brain response weighting filter $F_{\text{WF}}^{\text{LM}}(s)$. It can be obtained by applying the weighting filter $F_{\text{WF}}^{\text{V}}(s)$ of the voltage flickermeter, compensated for the analogue frequency response $F_{\text{RL}}(s)$ of the reference 60 W incandescent lamp (see Figure A.1):

$$F_{\text{WF}}^{\text{LM}}(s) = \frac{F_{\text{WF}}^{\text{V}}(s)}{F_{\text{RL}}(s)} \quad (\text{A.3})$$

The transfer function $F_{\text{WF}}^{\text{V}}(s)$ of the standard voltage flickermeter is defined in IEC 61000-4-15:2010, 5.5.

For the analogue frequency response $F_{\text{RL}}(s)$ of the reference 60 W incandescent lamp, the following 2nd order low-pass filter transfer function is used (see [7]):

$$F_{RL}(s) = \frac{K}{\tau_{L1} \cdot s^2 + \tau_{L2} \cdot s + 1} \quad (\text{A.4})$$

where

$K = 3,57$, $\tau_{L1} = 0,02$ ms, and

$\tau_{L2} = 21,2$ ms.

After substitution of Equation (A.4) into Equation (A.3) the weighting function $F_{WF}^{LM}(s)$ of the second part of block b can be written for a 230 V/50 Hz system as follows:

$$F_{WF}^{LM}(s) = \frac{0,041\,661 \cdot s^4 + 44,758 \cdot s^3 + 2\,715,6 \cdot s^2 + 29\,839 \cdot s}{s^4 + 196,32 \cdot s^3 + 11\,781 \cdot s^2 + 534\,820 \cdot s + 3\,505\,380} \quad (\text{A.5})$$

A.2.4 Block c: squaring multiplier, sliding mean filter and scaling

Block c has the same function as Block 4 of the flickermeter specified in IEC 61000-4-15:2010, 5.6.

The output of block c represents the instantaneous flicker sensation P_{inst} . In the IEC 6100-4-15 flickermeter, the output of block 4 is normalized using a scaling factor to give a value of $P_{inst} = 1$ during a 10 min flicker test, when a sine wave modulated 50 Hz input signal, with a modulation frequency of 8,8 Hz and a modulation depth of 0,25 % is applied (see [11] for more details). The scaling factor S accounts for the magnitudes of the frequency responses of all the filters applied.

Also for the light flickermeter such a scaling factor has to be applied. To obtain the S value for the light flickermeter, the illuminance waveform of an incandescent lamp subjected to the same voltage signal used in the adjustment of the IEC 61000-4-15 flickermeter, has to be applied:

$$E(t) = \{1 + (d_E / 2) \cdot \sin(2\pi f_m t)\} \quad (\text{A.6})$$

where

$E(t)$ is the relative illuminance that shall produce $P_{inst} = 1$ at the output of block c, see Equation (A.1),

$f_m = 8,8$ Hz and is the modulation frequency = $1/T_m$,

$d_E = 0,630$ % and is the relative change of the sinusoidal modulation of the illuminance in percentage.

NOTE The value of the illuminance relative amplitude ($d_E = 0,630$ %) was obtained from the average results of a sample of ten different 60 W incandescent lamps.

A.2.5 Block d: statistical analysis

Block d has the same function as Block 5 of the flickermeter specified in IEC 61000-4-15:2010, 5.7.

The output of block d represents the short-term flicker severity P_{st}^{LM} .

In order to ensure that the calculation of the short-term flicker severity P_{st}^{LM} is performed during the steady-state of the flickermeter's filters, the first 60 s of the instantaneous flicker

sensation P_{inst} , mainly corresponding to the transient response, should be discarded (see footnote c of Table 1).

A.3 Verification of the light flickermeter

The light flickermeter can be verified by applying standardized illuminance waveforms of which it has been demonstrated that it gives $P_{\text{st}}^{\text{LM}}$ -levels exactly equal to 1. This is done by applying a test voltage $u_{\text{E}}(t)$ that consists of a DC component plus a 100 Hz-ripple that is rectangular modulated as described in Equation (A.6) with the modulation parameters as given in Table A.1.

$$E(t) = \{1 - (d_r / 2) \cdot \cos(2\pi f_r t)\} \cdot \{1 + (d_E / 2) \cdot \text{signum}(\sin(2\pi f_m t))\} \quad (\text{A.7})$$

where

$E(t)$ is the relative illuminance; see Equation (A.1),

f_r equals 100 Hz and is the frequency of an illuminance ripple added to the DC value,

f_m is the modulation frequency = $1/T_m$,

d_r equals 22 % and is the relative change of the 100 Hz-illuminance ripple in percent,

d_E is the relative change of the rectangular modulation of the illuminance in percent,

$\text{signum}(x)$ = the signum function, $\text{signum}(x) = 1$ for $x > 0$

$\text{signum}(x) = 0$ for $x = 0$

$\text{signum}(x) = -1$ for $x < 0$.

All test frequency and relative illuminance level combinations should give a short-term flicker value of exactly $P_{\text{st}}^{\text{LM}} = 1$ when applied to the light flickermeter.

Table A.1 – Test specification of illuminance fluctuations for lightmeter classifier

Rectangular amplitude modulations with duty cycle of 50 %; see Equation (A.7)		
Changes per minute	Modulation frequency	Relative illuminance change
cpm	f_m Hz	d_E %
39	0,325 0	2,538 6
110	0,916 7	2,047 3
1 056	8,8	0,683 2
1 620	13,5	0,778 0
4 000	33,3	2,002 7

A.4 Example of $P_{\text{st}}^{\text{LM}}$ implementation in MATLAB®

An example of $P_{\text{st}}^{\text{LM}}$ implementation is given on MATLAB Central [21].

Annex B (informative)

Uncertainty considerations

B.1 General

Annex B gives information related to uncertainty of the P_{st}^{LM} result of a voltage fluctuation immunity test. General information on uncertainty considerations of immunity tests can be found in IEC 61000-1-6 (see Clause B.6).

B.2 General symbols

X_i	influence quantity
x_i	estimate of influence quantity X_i
δX_i	correction for influence quantity
$u(x_i)$	standard uncertainty of x_i
c_i	sensitivity coefficient
y	result of a measurement (the estimate of the measurand), corrected for all recognized significant systematic effects
$u_c(y)$	combined standard uncertainty of y
$U(y) = k \cdot u_c(y)$	expanded uncertainty of y
k	coverage factor = 2

B.3 Measurand

The measurand associated with the voltage fluctuation immunity test is P_{st}^{LM} , the short-term flicker metric.

B.4 Influence quantities

Table B.1 gives the list of influence quantities that should be considered to derive the overall uncertainty of P_{st}^{LM} .

All the influence quantities of the mains supply and the disturbance may be integrated into one uncertainty value of the P_{st}^V level associated with the test voltage.

The EUT is an important, but also a difficult source of uncertainty, because the correction may vary significantly as a function of EUT technology. Generally the correction factor for SSL types of EUTs is much less than 1. This means that uncertainty contribution from the EUT is damped. For an incandescent lamp, the correction factor is 1. This means that the uncertainty of the mains supply voltage and its voltage fluctuation disturbance is transferred to the outcome of the test with a gain of 1.

For the sake of simplicity, in the remainder of Annex B the uncertainty budget will be considered only for the reference 60 W incandescent lamp.

Table B.1 – Influence quantities and their recommended tolerances

Main category	Subcategory	Importance	Nominal value	Recommended tolerance/value
Mains supply	Nominal voltage	Minor	230 V	±0,5 %
	Frequency	Minor	50 Hz	±0,5 %
Voltage fluctuation	Waveshape (transition time)	Minor		< 0,5 ms
	Modulation frequency	Minor	See Table 1	±1 %
	Relative voltage fluctuation	Relatively important	See Table 1	±5 %
	Duty cycle	Minor	50 %	±2 pp
	Noise level of the relative voltage fluctuation	Minor if $d < 0,0275$ % (0,1 times lowest value d)	n.a.	< 0,055
P_{st}^V of the voltage fluctuation	Replaces all above given influence quantities for the voltage fluctuation	Relatively important	1	±5 %
	Noise level	Relatively important	n.a.	< 0,2
EUT	Technology	For a 60 W incandescent lamp, the voltage fluctuation is linearly transferred	n.a.	n.a.
	Warming-up time	Can be made negligible, but may be important, if ignored	Technology dependent	n.a.
	Dimming level	Important	50 % of max. light output	±10 %
Light sensor, filter and amplifier	Sensitivity	Minor if nominal levels are well above noise level		
	Linearity/offset	Generally minor		
	Optical filter	Minor if compliant with CIE sensitivity curve		
	Bandwidth	Minor if > recommended value	2 kHz	n.a.
Test environment	Optical noise	Can be made negligible	0	n.a.
	EM disturbances	Can be made negligible	0	n.a.
Test procedure	Duration test	Minor if larger than both the transient of the lightmeter filter and the time period T_m corresponding to the modulation frequency	In relation to modulation frequency	
	Sampling rate	Minor, if the rate satisfies the recommended value in conjunction with a suitable anti-aliasing filter		
Light flickermeter	Noise level		0	< 0,1
	Implementation uncertainty	To be determined by verification test	$P_{st} = 1/4, 1/2, 1, 2, 3, 4, 5$	±5 %

B.5 Uncertainty budget

The second step in assessing uncertainty is to specify a mathematical model that combines the aggregate effect of the major influence quantities on the overall uncertainty to estimate the combined standard uncertainty u_c . A simple multiplicative model will suffice for most scenarios. The model:

$$P_{st} = P_{st}^0 \cdot G_1 \cdot G_2 \cdots G_N \quad (\text{B.1})$$

where:

P_{st}^0 is the true value

P_{st} is the measured value

$G_1 G_2 \dots G_N$ are multiplicative corrections (with associated uncertainties) due to the major influence quantities.

In the case of testing an incandescent lamp, the major uncertainty contributions are

- the uncertainty resulting from the test voltage (TV): δP_{st}^{TV} ;
- the uncertainty of the light flickermeter (LFM): δP_{st}^{LFM} ;
- the uncertainty due to the noise (N) of the test voltage: δP_{st}^N .

The overall uncertainty, can then be expressed as:

$$P_{st} = P_{st}^{LFM} \cdot (1 \pm \delta P_{st}^{TV}) \cdot (1 \pm \delta P_{st}^{LFM}) \cdot (1 + \delta P_{st}^N) \quad (\text{B.2})$$

Subsequently, the expanded uncertainty is calculated in the logarithmic domain (see IEC 61000-1-6 for details).

The tolerances of the light flickermeter and the test voltage, respectively $\pm 0,05$ and $\pm 0,02$, can be applied directly in the uncertainty budget with the same magnitude (normal distribution).

The uncertainty contribution from the test voltage fluctuation noise level (0,2) can be estimated as follows. The combination of two illuminance fluctuations having different fluctuation frequencies follow the quadratic addition law (Aileret), see Equation (3) in [10]. Hence, for an incandescent lamp, the combination of two voltage fluctuations also follows the quadratic summation law. Therefore, the uncertainty resulting from adding a residual (noise) voltage fluctuation to a wanted voltage fluctuation level can be calculated from

$$\delta P_{st}^N = \sqrt{(0,2)^2 + 1^2} - 1 \approx 0,02 .$$

When filling out the three major contributions to the uncertainty, the uncertainty budget given in Table B.2 is obtained.

Hence, the expanded uncertainty for P_{st} is $U_c = \pm 0,07$. The two major contributors to the uncertainty are the light flickermeter and the test voltage.

Table B.2 – Uncertainty budget of the voltage fluctuation immunity test

Input quantity	x_i	Uncertainty of x_i (plus/minus)	Uncertainty of x_i				$c_i u(x_i)$ (minus)	$c_i u(x_i)$ (plus)
			(minus)	(plus)				
		linear	dB	dB	Probability distribution function	divisor k	dB	dB
Uncertainty light flickermeter	δP_{st}^{LFM}	0,05	–0,5	0,42	normal	2	–0,22	0,21
Uncertainty from the test voltage	δP_{st}^{TV}	0,05	–0,45	0,42	normal	2	–0,22	0,21
Uncertainty test voltage noise	δP_{st}^N	0,02	0,00	0,17	normal	2	0,00	0,09
Combined standard uncertainty (SCU)	u_c						0,32	0,31
Expanded uncertainty	U_c	0,07					0,63	0,62
All sensitivity coefficients c_i are assumed to be equal to 1.								

Annex C (informative)

Examples of test results of lighting equipment

C.1 Test without voltage fluctuations

P_{st}^{LM} measurement results for three types of lighting equipment are given in Table C.1. No voltage modulation is present on the mains i.e. measurements have been performed with a stable source.

**Table C.1 – Numerical results P_{st}^{LM} calculations
for three EUTs without voltage modulation**

EUT	Type	P_{st}^{LM}
1	60 W incandescent lamp	0,025
2	9 W self-ballasted CFL lamp	0,023
3	7 W self-ballasted LED lamp	0,028

C.2 Test with (intentional) voltage fluctuations

P_{st} measurement results for three types of lighting equipment are given in Table C.2. Voltage modulations in accordance with Table 1 have been applied to the mains.

**Table C.2 – Numerical results P_{st}^{LM} calculations
for three EUTs with voltage modulation**

EUT	Modulation frequency	Relative voltage fluctuation	P_{st}^{LM}
	Hz	%	
1 60 W incandescent lamp	0,325 0	0,894	1,005
	0,916 7	0,722	1,005
	8,8	0,275	1,009
	13,5	0,407	1,013
	33,3	2,343	1,042
2 9 W self- ballasted CFL lamp	0,325 0	0,894	0,217
	0,916 7	0,722	0,208
	8,8	0,275	0,234
	13,5	0,407	0,284
	33,3	2,343	0,536
3 7 W self- ballasted LED lamp	0,325 0	0,894	0,167
	0,916 7	0,722	0,166
	8,8	0,275	0,188
	13,5	0,407	0,239
	33,3	2,343	0,466

From the results for these specific EUTs one may conclude that EUT2 and EUT3 (respectively CFL and LED lamps) are more immune to voltage fluctuations than the reference incandescent lamp EUT1.

The results of Table C.2 are also depicted in Figure C.1.

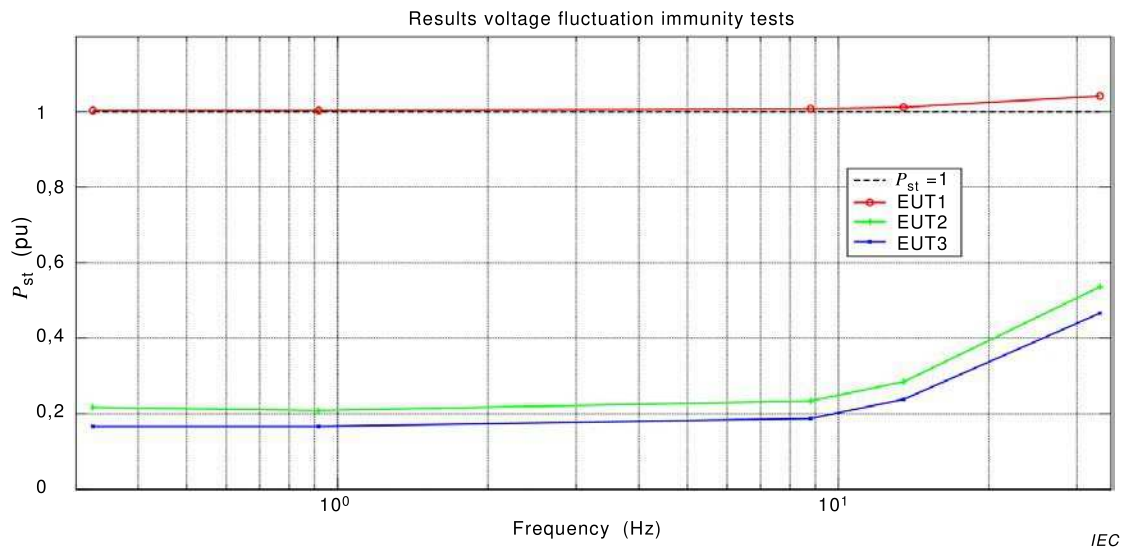
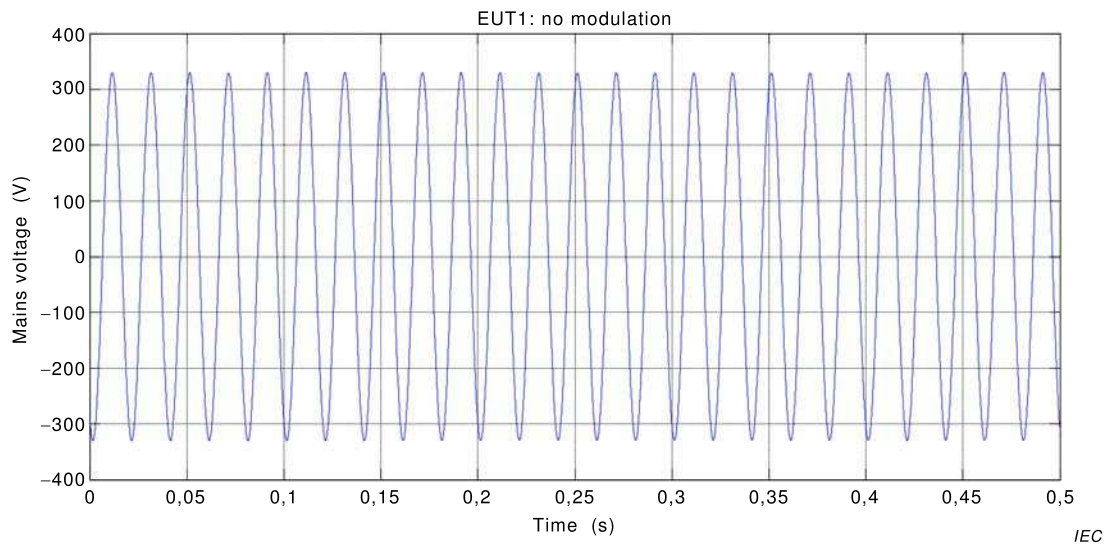
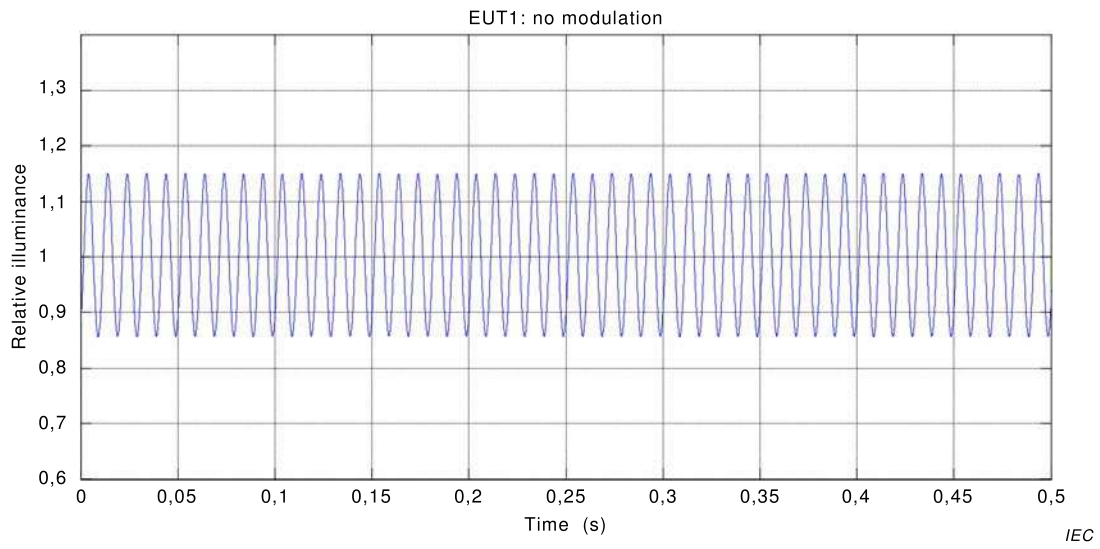

Figure C.1 – Graphical P_{st}^{LM} results for three EUTs with rectangular modulation at five frequencies ($P_{st}^V = 1$)

Records have been made for 60 s with a sampling rate of 10 kHz. Snapshots of the recorded signals for EUT1 without mains voltage modulation and with modulation are given respectively in Figure C.2 and Figure C.3. Results of recorded illuminance signals for EUT2 and EUT3 with mains voltage modulation are given in Figure C.4 and Figure C.5.



a) Mains signal



b) Relative illuminance

Figure C.2 – EUT1: recorded signals (no mains voltage modulation)

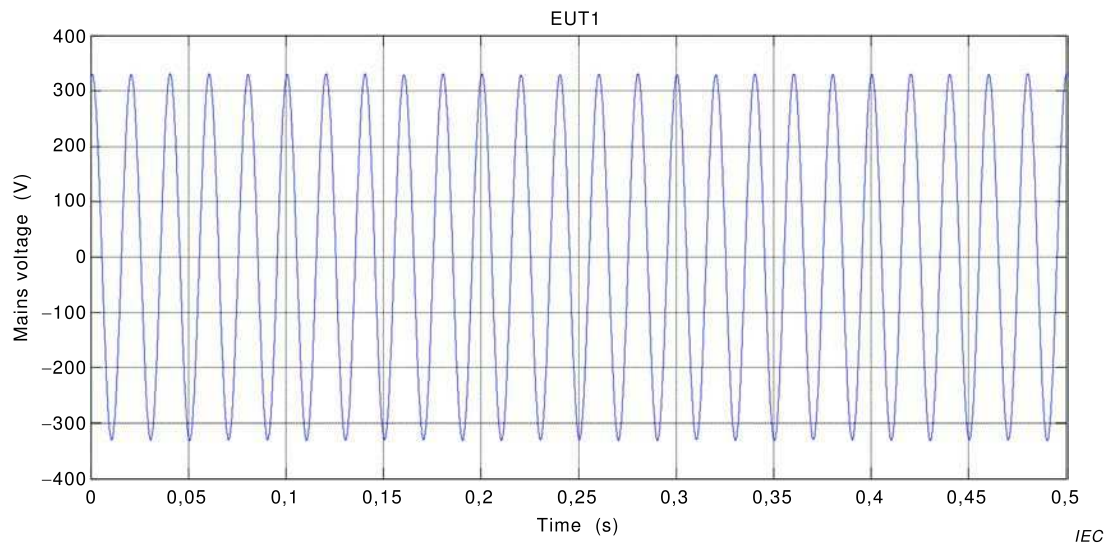

a) Mains signal with modulation $d = 0,407\%$ at $13,5\text{ Hz}$ ($P_{st}^V = 1$)

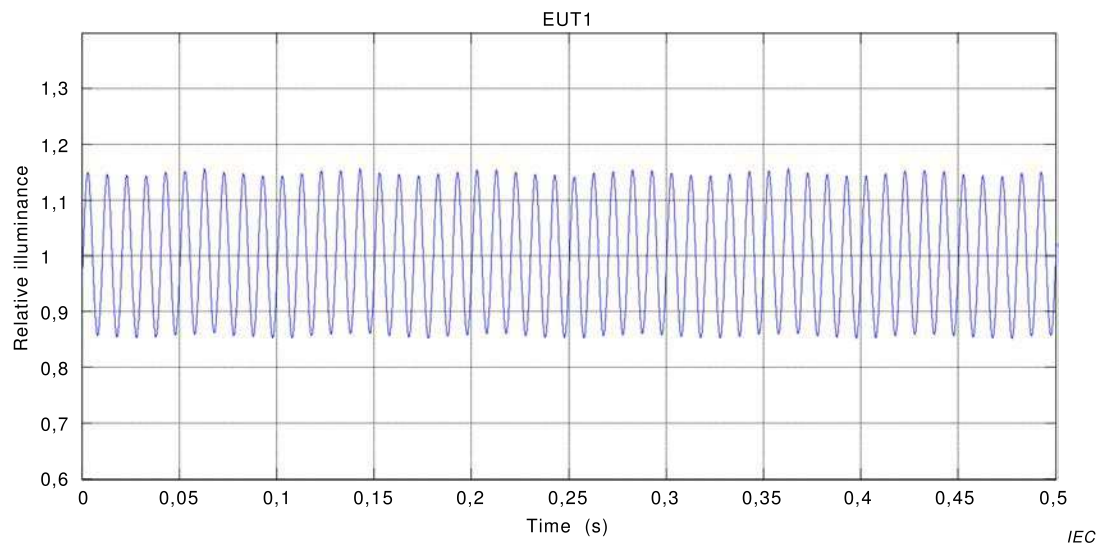

b) Relative illuminance

Figure C.3 – EUT1: recorded signals (with modulation)

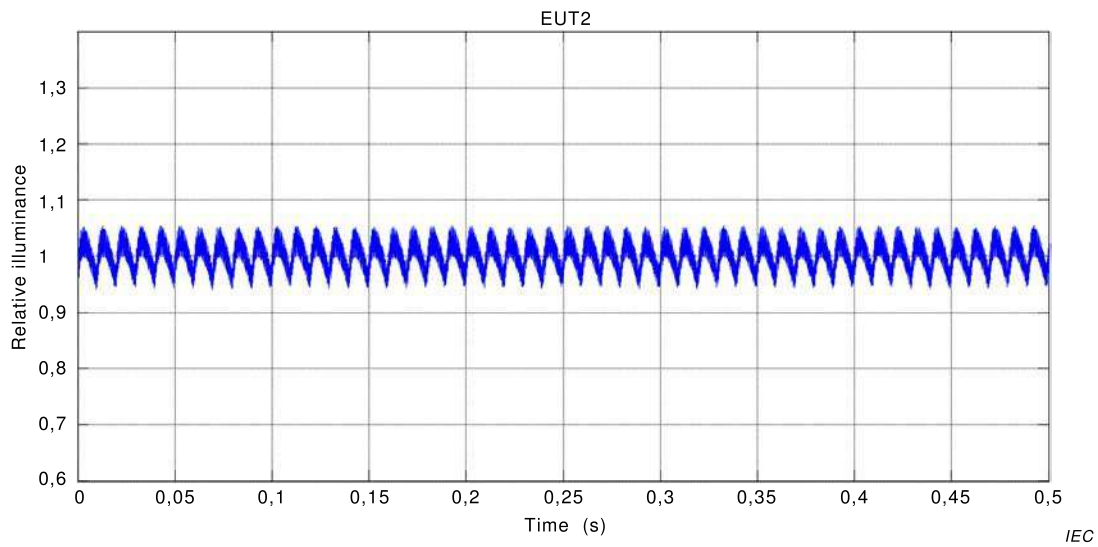

**Figure C.4 – EUT2: relative illuminance:
mains voltage modulation $d = 0,407\%$ at $13,5\text{ Hz}$ ($P_{st}^V = 1$)**

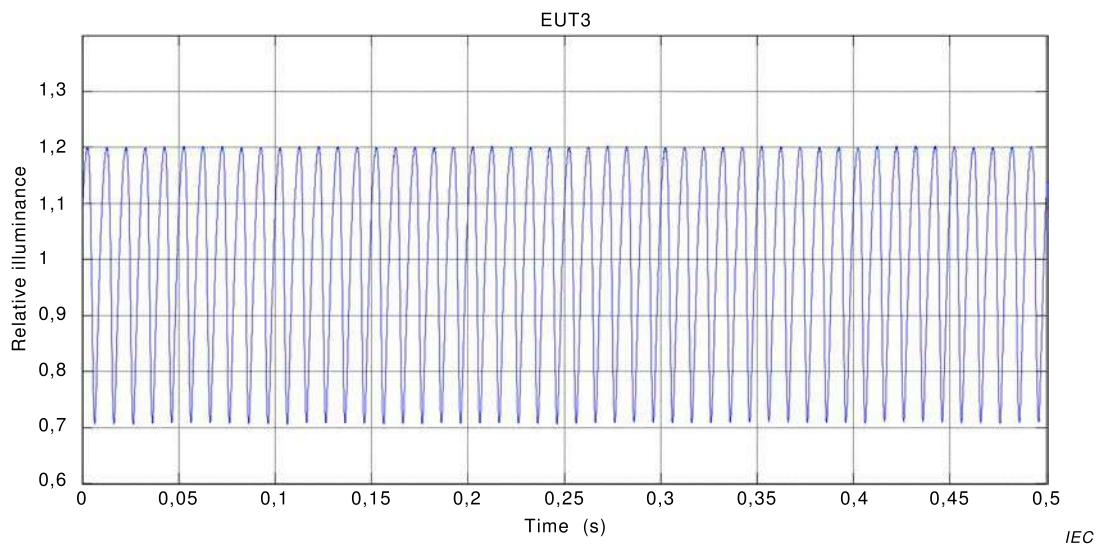

**Figure C.5 – EUT3: relative illuminance:
mains voltage modulation $d = 0,407\%$ at $13,5\text{ Hz}$ ($P_{st}^V = 1$)**

C.3 Test under dimming conditions

P_{st} measurement results for four types of lighting equipment under dimming conditions are given in Table C.3. Dimming level 1 indicates maximum dimming (thus minimum light output), whereas dimming level 4 indicates minimum dimming (thus maximum light output).

Table C.3 – Numerical results P_{st}^{LM} calculations for four EUTs under dimming conditions

Dimming	P_{st}^{LM}			
	60 W incandescent lamp	20 W self-ballasted CFL lamp	12 W self-ballasted LED lamp	10 W self-ballasted LED lamp
Level 1	0,270	0,359	0,675	0,539
Level 2	0,132	0,084	0,251	0,165
Level 3	0,081	0,037	0,050	0,086
Level 4	0,024	0,005	0,038	0,043

The values of P_{st}^{LM} given in Table C.3 are depicted graphically in Figure C.6.



Figure C.6 – Graphical P_{st}^{LM} results for four EUTs under dimming conditions

From the results for these specific EUTs one may conclude that increasing the dimming level causes an increase in the measured P_{st} level. Note that the tests have been performed under stable mains voltage conditions i.e. there are no voltage fluctuations applied on the mains.

Bibliography

- [1] IEC 61547:2009, *Equipment for general lighting purposes – EMC immunity requirements*
- [2] IEC 61547:2009/ISH1:2013, *Interpretation sheet 1 – Equipment for general lighting purposes - EMC immunity requirements*
- [3] ISO 11664-1:2007 (CIE S 014-1/E:2006), *Colorimetry – Part 1: CIE standard colorimetric observers³*
- [4] I. Azcarate, J.J. Gutierrez, A. Lazkano, P. Saiz, L.A. Leturiondo, K. Redondo, *Sensitivity to flicker of dimmable and non-dimmable lamps , Instrumentation and Measurement Technology Conference (I2MTC), 2012 IEEE International, 13-16 May 2012, pp. 344 – 347*
- [5] K. Chmielowiec, *Flicker effects of different types of light sources*, 2011 11th International Conference on Electrical Power Quality and Utilisation (EPQU), 17-19 Oct. 2011
- [6] I. Azcarate J.J. Gutierrez, A. Lazkano, L.A. Leturiondo, P. Saiz, K. Redondo, J. Barros, *Type testing of a highly accurate illuminance flickermeter*, ICHQP 2012
- [7] J. Drápela, J. Šlezinger, *A light-flickermeter – Part I: Design*, Proceedings 11th International Scientific Conference Electric Power Engineering 2010, pp. 453
- [8] J. Drápela, J. Šlezinger, *A light-flickermeter – Part II: Realization and verification*, Proceedings 11th International Scientific Conference Electric Power Engineering 2010, pp. 459
- [9] T. Keppler, T. Keppler, N. R. Watson, S. Chen and J. Arrillaga, *Digital flickermeter realisations in the time and frequency domain*, Proceedings of the Australasian Universities Power Engineering Conference (AUPEC-2001), 23-26 September 2001, pp. 565
- [10] J. Ruiz, J. J. Gutierrez, A. Lazkano, S. Ruiz de Gauna, *A Review of Flicker Severity Assessment by the IEC Flickermeter*, IEEE Transactions on Instrumentation and Measurement, vol. 59, NO. 8, August 2010, pp. 2037
- [11] Testing the NPL flickermeter: www.npl.co.uk/electromagnetics/electrical-measurement/products-and-services/testing-the-npl-reference-flickermeter
- [12] R. A. Losada, *Digital Filters with MATLAB*, The MathWorks, Inc., 11 May 2008 (Updated 16 Dec 2009): <http://www.mathworks.com/matlabcentral/fileexchange/19880-digital-filters-with-matlab>
- [13] Solcept Open Source Flicker Measurement-Simulator, <https://www.solcept.ch/en/tools/flickersim/download/>
- [14] P. Jourdan, *Flickermeter Simulator: Power line flickermeter according IEC 61000-4-15*, Matlab Central, 12 Jun 2009 (Updated 11 Jan 2010): www.mathworks.com/matlabcentral/fileexchange/24423-flickermeter-simulator

³ ISO 11664-1:2007 specifies colour-matching functions for use in colorimetry. Two sets of colour-matching functions are specified: colour-matching functions for the CIE 1931 standard colorimetric observer and colour-matching functions for the CIE 1964 standard colorimetric observer. The colour-matching functions for the CIE 1931 standard colorimetric observer is to be applied.

- [15] IEC 60050 (all parts), *International Electrotechnical Vocabulary* (available at <http://www.electropedia.org/>)
- [16] J. J. Gutierrez, P. Beeckman, I. Azcarate, *A protocol to test the sensitivity of lighting equipment to voltage fluctuations*, 23rd International Conference on Electricity Distribution: CIRED 2015, Lyon, June 2015.
- [17] CIGRE Report 656:2016, Review of LV and MV Compatibility levels for voltage fluctuations, Working Group C4.111, dated May 2016.
- [18] D. Sekulovski, *Is it all flicker?*, <https://www.youtube.com/watch?v=1gZg6eUmEGA>, Webinar dd. 2016-03-24
- [19] EC SCENIHR (Scientific Committee on Emerging and Newly Identified Health Risks), *Health Effects of Artificial Light*, 19 March 2012: http://ec.europa.eu/health/scientific_committees/consultations/public_consultations/scenihr_consultation_14_en.htm
- [20] IEC TR 61000-1-6:2012, *Electromagnetic compatibility (EMC) – Part 1-6: General – Guide to the assessment of measurement uncertainty*
- [21] PstLM toolbox MATLAB Central, <https://nl.mathworks.com/matlabcentral/fileexchange/63445-light-flicker-assessment-toolbox?requestedDomain=www.mathworks.com>
- [22] CIE TN 006:2016, *Visual Aspects of Time-Modulated Lighting Systems – Definitions and Measurement Models*
-

INTERNATIONAL
ELECTROTECHNICAL
COMMISSION

3, rue de Varembé
PO Box 131
CH-1211 Geneva 20
Switzerland

Tel: + 41 22 919 02 11
Fax: + 41 22 919 03 00
info@iec.ch
www.iec.ch